

# Round cylinder, Series RPC

- Version: compact type
- Ø 32-63 mm
- Ports G 1/8 G 1/4 G 3/8
- double-acting
- with magnetic piston
- Cushioning elastic non-adjustable
- with integrated rear eye
- Piston rod External thread



Compressed air connection	Internal thread
Working pressure min./max.	1 ... 10 bar
Ambient temperature min./max.	-20 ... 80 °C
Medium temperature min./max.	-20 ... 80 °C
Medium	Compressed air
Max. particle size	50 µm
Oil content of compressed air	0 ... 5 mg/m <sup>3</sup>
Pressure for determining piston forces	6.3 bar



## Technical data

Piston Ø Piston rod thread Ports Piston rod Ø	32 mm M10x1,25 G 1/8 12 mm	40 mm M12x1,25 G 1/4 16 mm	50 mm M16x1,5 G 1/4 20 mm	63 mm M16x1,5 G 3/8 20 mm
Stroke 25	R412020684	R412020695	R412020706	R412020717
50	R412020685	R412020696	R412020707	R412020718
80	R412020686	R412020697	R412020708	R412020719
100	R412020687	R412020698	R412020709	R412020720
125	R412020688	R412020699	R412020710	R412020721
160	R412020689	R412020700	R412020711	R412020722
200	R412020690	R412020701	R412020712	R412020723
250	R412020691	R412020702	R412020713	R412020724
320	R412020692	R412020703	R412020714	R412020725
400	R412020693	R412020704	R412020715	R412020726
500	R412020694	R412020705	R412020716	R412020727

## Technical data

Piston Ø	32 mm	40 mm	50 mm	63 mm
Retracting piston force	435 N	660 N	1035 N	1765 N
Extracting piston force	505 N	790 N	1235 N	1960 N
Impact energy	0,8 J	1,04 J	1,28 J	1,5 J
Weight 0 mm stroke	0,33 kg	0,58 kg	0,92 kg	1,62 kg
Weight +10 mm stroke	0,015 kg	0,024 kg	0,04 kg	0,044 kg
Stroke max.	1200 mm	1200 mm	1200 mm	1200 mm

## Technical information

The pressure dew point must be at least 15 °C under ambient and medium temperature and may not exceed 3 °C .

The oil content of compressed air must remain constant during the life cycle.

Use only the approved oils from AVENTICS. Further information can be found in the "Technical information" document (available in the MediaCentre).

Clamping piece for magnetic field sensor necessary

## Technical information

Material	
Cylinder tube	Stainless steel
Piston rod	Stainless steel
Piston	Aluminum
Front cover	Aluminum, anodized
End cover	Aluminum, anodized
Seal	Polyurethane
Nut for piston rod	Steel, galvanized
Scraper	Polyurethane
Guide bushing	Steel

## Dimensions

### Dimensions

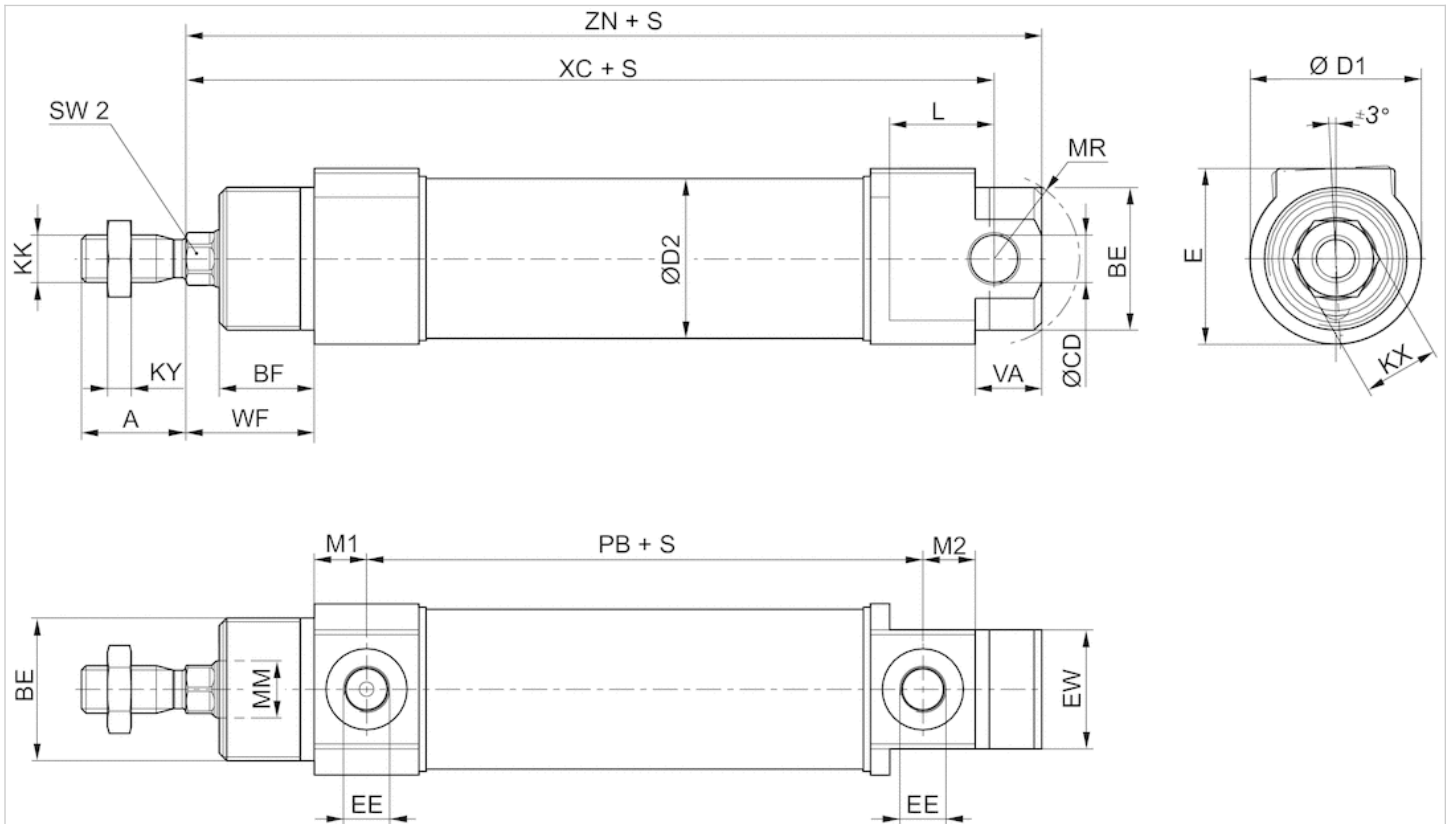

S=stroke

## Dimensions

Piston Ø	A	BE	BF	Ø CD H8	Ø D1	Ø D2	E	EE	EW	KK	KX	KY	L 1)
32 mm	22	M30x1,5	20	10	36	33.5	37	G 1/8	25	M10x1,25*	16	5	22
40 mm	24	M38x1.5	23	12	45	41.5	45	G 1/4	30	M12x1,25*	19	6	23
50 mm	32	M45x1,5	24	12	55	52.5	55	G 1/4	35	M16x1,5	24	8	26
63 mm	32	M45x1,5	26.5	16	69	65.4	69	G 3/8	35	M16x1,5	24	8	29

Piston Ø	Ø MM f8	M1	M2	MR	PB	SW2	VA	WF	XC	ZN
32 mm	12	11	11	18	67	10	14	27	120	130
40 mm	16	11.5	11.5	22.5	78	13	15	32	136	147
50 mm	20	11.5	11.5	25.5	77.5	17	18	33.5	141	152
63 mm	20	13.5	13.5	36.5	81.5	17	20	36.5	151	165

\* Use our Internet configurator to order these variants with coarse-pitch thread M10x1.5 or M12x1.75.

1) Min.

## Accessories overview

### Overview drawing

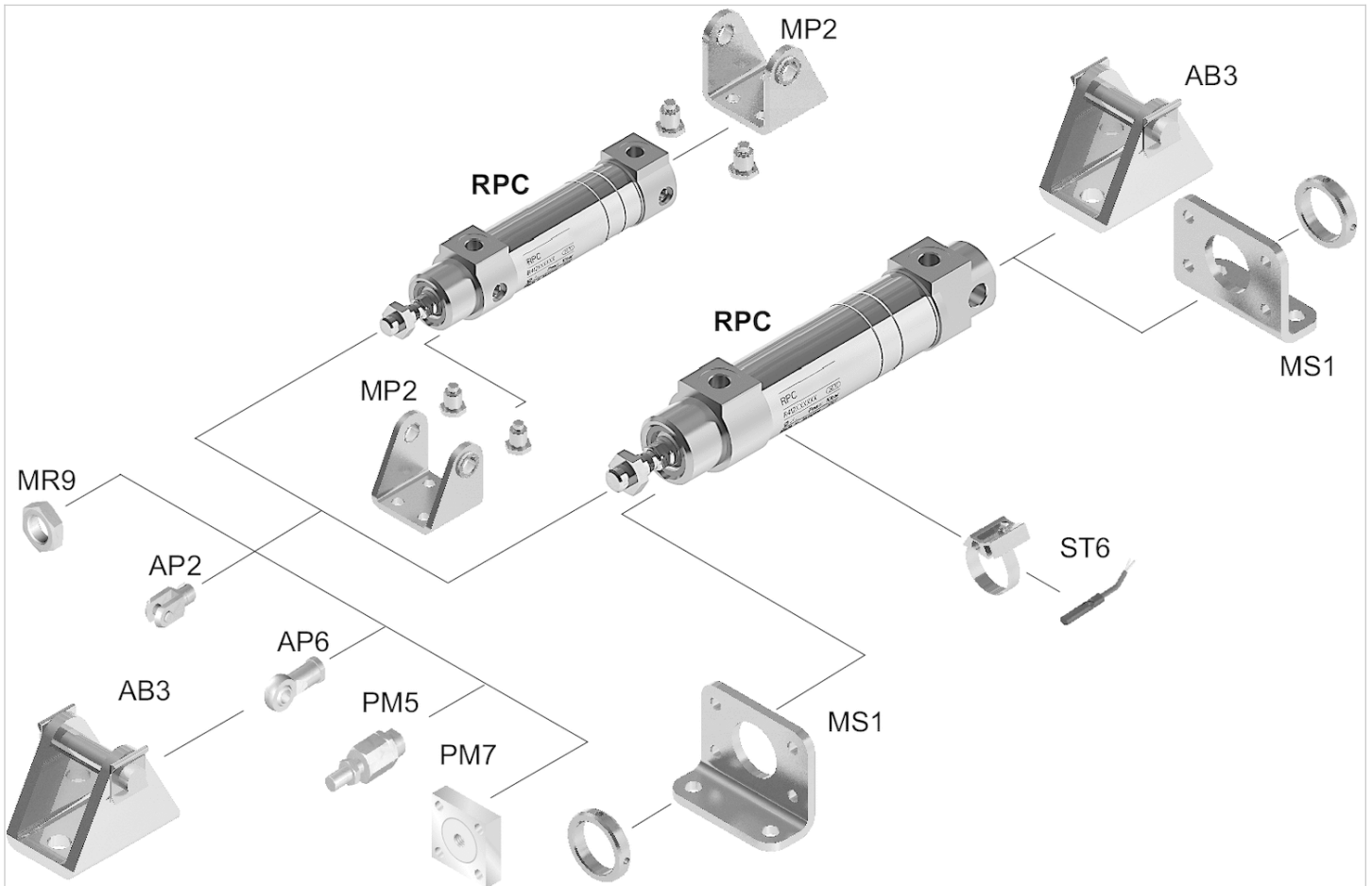

NOTE: This overview drawing is only for orientation to indicate where the various accessory parts can be fastened to the cylinder. The illustration has been simplified for this purpose. It is thus not possible to derive the dimensions from this overview.